

Fundamentals of Computational Neuroscience 2e

Thomas Trappenberg

December 11, 2009

Chapter 9: Modular networks, motor control, and reinforcement
learning

Mixture of experts

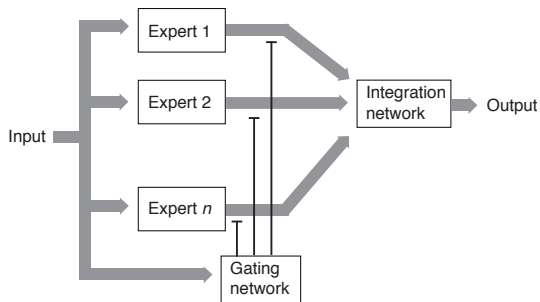

A. Absolute function

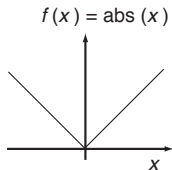

B. Mixture of expert for absolute function

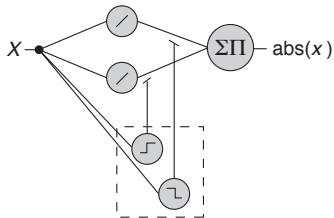

The 'what-and-where' task

A. Model retina with sample image

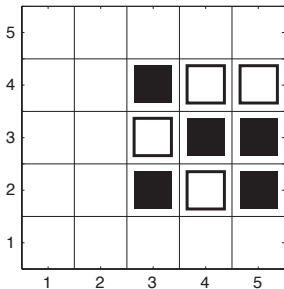

B. Without bias towards short connections

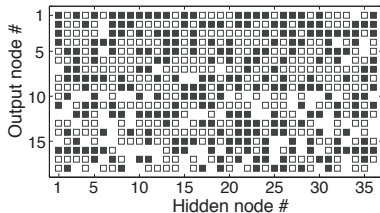

C. With bias towards short connections

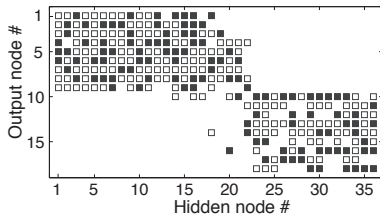

Jacobs and Jordan (1992)

Coupled attractor networks

A. Coupled attractor networks

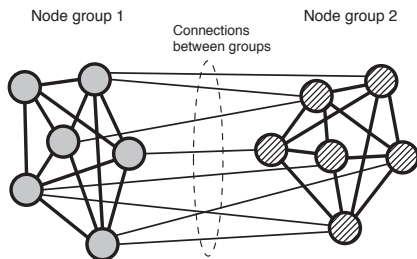

B. The left-right universe with letters

000011100000	111111110000
000011100000	111111111100
000011110000	111000000110
000110110000	111000011100
000110001000	1110001110000
0011100011100	1111111000000
0011111111100	1111111000000
0111111111110	1110001110000
0111000001110	1110000011100
0111000001110	1110000001110
0111000001110	1111111111100
0111000001110	1111111110000

Limit on modularity

A. Load capacity

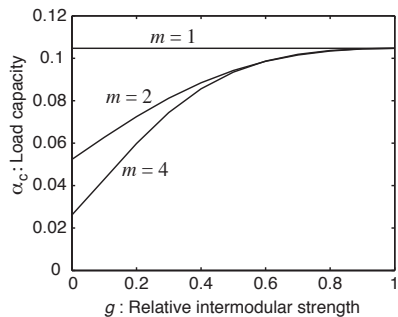

B. Bounds on intermodular strength

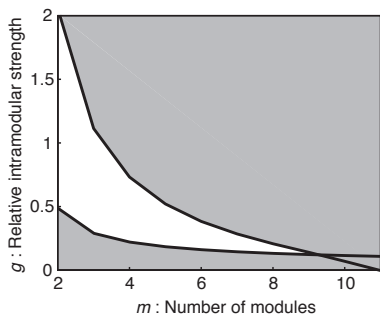

Sequence learning

A. Modular attractor model

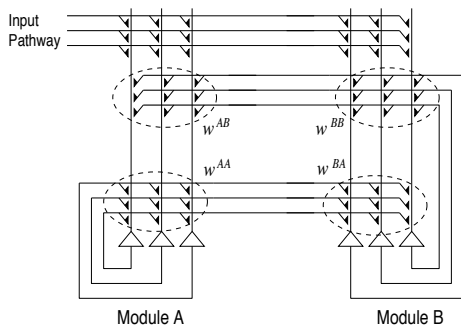

B. Time evolution of overlaps

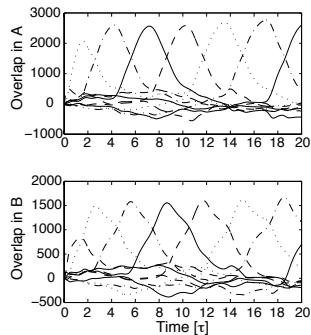

Lawrence, Trappenberg and Fine (2006); (Sommer and Wennekers (2005))

Working memory

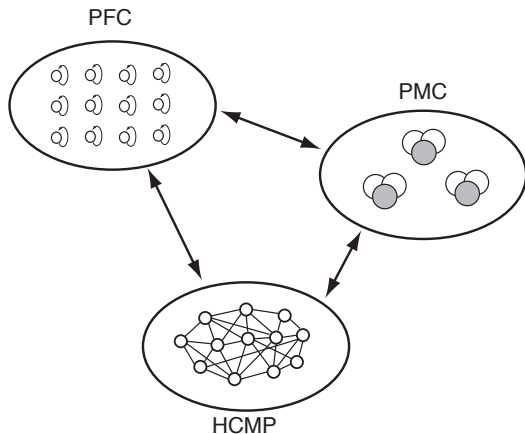

O'Reilly, Braver, and Cohen 1999

Limit on working memory

A. One object

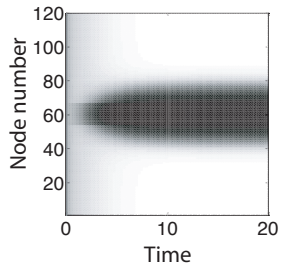

B. Two objects

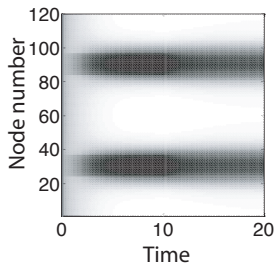

C. Four objects

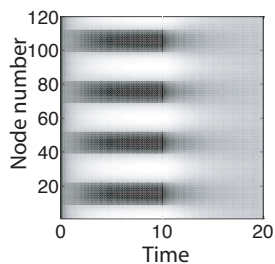

Motor learning and control

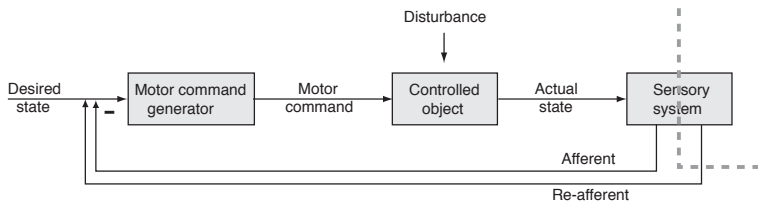

Forward model controller

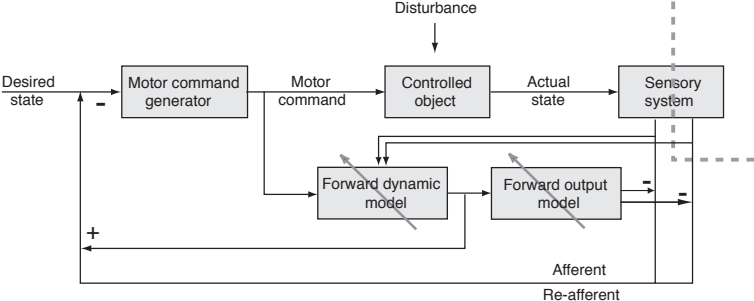

Inverse model controller

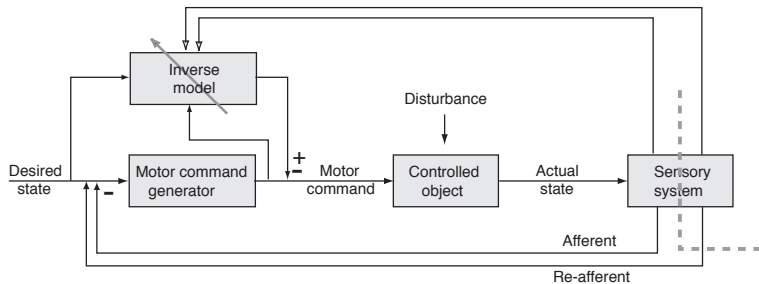

Cerebellum

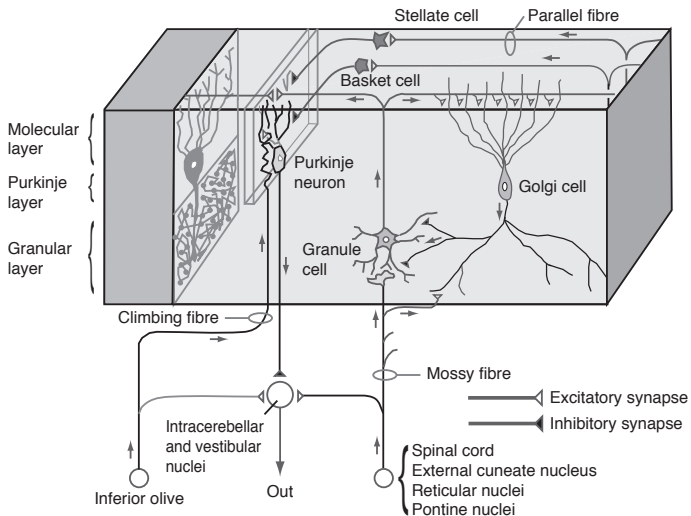

Reinforcement learning

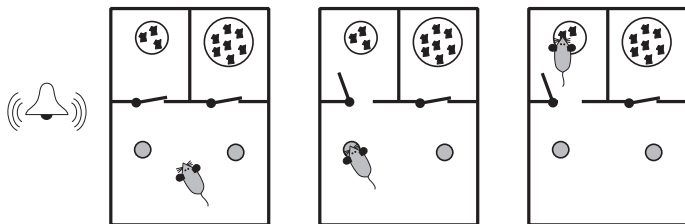

Basal Ganglia

A. Outline of basic BG anatomy

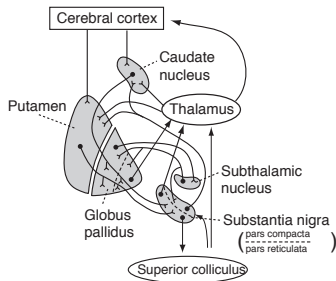

C. Recordings of SNc neurons and simulations

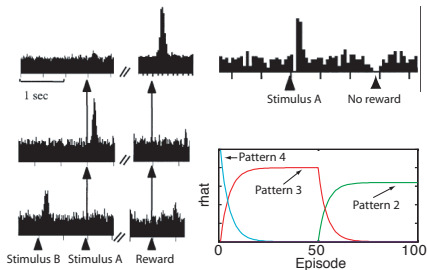

temporal difference learning

A. Linear predictor node

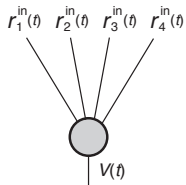

B. Temporal delta rule

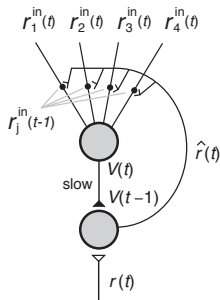

C. Temporal difference rule

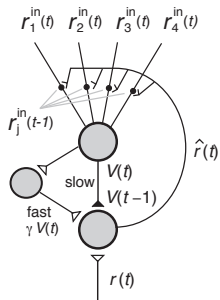

Actor-critique and Q-learning

B. Actor-critic model of BG

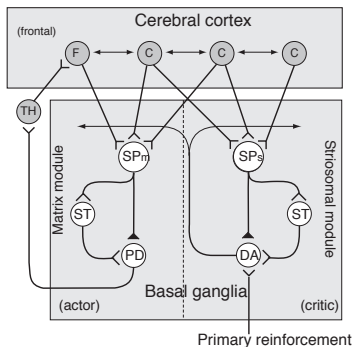

D. Q-learning model of BG

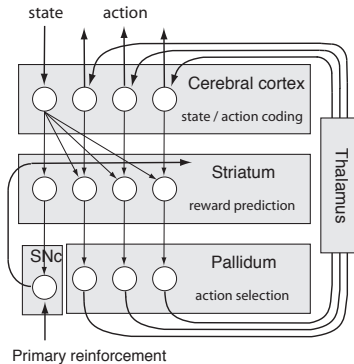

Actor-critique controller

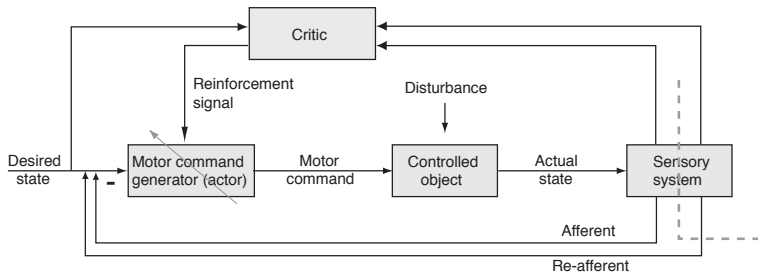

Further Readings

- Robert A. Jacobs, Michael I. Jordan, and Andrew G. Barto (1991), **Task decomposition through competition in a modular connectionist architecture: the what and where tasks**, in **Cognitive Science** 15: 219–250.
- Geoffrey Hinton (1999), **Products of experts**, in **Proceedings of the Ninth International Conference on Artificial Neural Networks**, ICANN '99, 1:1–6.
- Yaneer Bar-Yam (1997), **Dynamics of complex systems**, Addison-Wesley.
- Edmund T. Rolls and Simon M. Stringer (1999), **A model of the interaction between mood and memory**, in **Networks: Computation in neural systems** 12: 89–109.
- N. J. Nilsson (1965), **Learning machines: foundations of trainable pattern-classifying systems**, McGraw-Hill.
- O. G. Selfridge (1958), **Pandemonium: a paradigm of learning, in the mechanization of thought processes**, in **Proceedings of a Symposium Held at the National Physical Laboratory**, November 1958, 511–27, London HMSO.
- Marvin Minsky (1986), **The society of mind**, Simon & Schuster.
- Akira Miyake and Priti Shah (eds.) (1999), **Models of working memory**, Cambridge University Press.
- Daniel M. Wolpert, R. Chris Miall, and Mitsuo Kawato (1998), **Internal models in the cerebellum**, in **Trends Cognitive Science** 2: 338–47.
- Edmund T. Rolls and Alessandro Treves (1998), **Neural networks and brain function**, Oxford University Press.
- James C. Houk, Joel L. Davis, and David G. Beiser (eds.) (1995), **Models of information processing in the basal ganglia**, MIT Press.
- Richard S. Sutton and Andrew G. Barto (1998), **Reinforcement learning: an introduction**, MIT Press.
- Peter Dayan and Laurence F. Abbott (2001), **Theoretical Neuroscience**, MIT Press.